

# CliniMix® Thermostatic Mixing Valve 15mm Inlet and 15/20 BSP Outlet

PRODUCT CODE:

- WM-TMV1



## TABLE OF CONTENTS

Introduction .....	1
Product Range And Physical Description .....	2
Technical Data.....	3
Flow Sizing Graph.....	3
Installation .....	4
Commissioning Of The Valve .....	5
Maintenance And Servicing .....	6
Spare Parts .....	8
Warranty.....	9
Troubleshooting.....	10

## INTRODUCTION

The Galvin Specialised CliniMix® Thermostatic Mixing Valve is a high performance Thermostatic Mixing Valve (TMV) suitable for a wide range of applications. The TMV is designed to comply with 'AS4032.1 Thermostatic Mixing Values-Materials, Design and Performance Requirements' and 'NSW Health Department' requirements. The CliniMix® Mixing Valve has the following features:

- Complies with the requirements of AS4032.1 – Thermostatic Mixing Valves;
- Provides high stability of mixed water temperature even under changing inlet conditions;
- Ensures rapid shut down of mixed outlet flow in the event of hot or cold water supply failure;
- Designed for quick and simple in-situ servicing;
- Suitable for installation into AS/NZS 3500 compliant systems with hot water temperature at low as 55° Celsius;
- Fitted with tamper resistant temperature adjustment mechanism.

## SAFETY

The Galvin Specialised CliniMix® Thermostatic Mixing Valve is a high-performance valve designed to give stable and dependable operation, provided it is installed, commissioned, operated and maintained as per the recommendations outlined in this manual. It should be noted however that this TMV should not be considered as an alternative to adequate supervision and duty of care during its use and operation.

**Note:** The TMV, inlet controls, pipe work and the surrounding area may become hot when installed which may cause burn injuries. Precautions should be taken to ensure that these surfaces cannot cause such injuries.

## PRODUCT RANGE AND PHYSICAL DESCRIPTION

The Galvin Specialised CliniMix<sup>®</sup> Thermostatic Mixing Valve is supplied complete with inlet service fittings. The inlets to the fitting are 1/2" BSP male, and the outlet from the TMV is a 1/2" BSP male adaptor with an optional 3/4" BSP male adaptor. The service fittings consist of isolating ball valves, strainers, pressure test points and non-return valves. The strainers can be serviced and cleaned without disturbing the installation (refer to Section 8). The inlet service fittings also incorporate union type fittings enabling the thermostatic mixing valve to be removed from its installation without disturbing its pipe work.

The schematics and dimensions of the valve and corresponding order code are shown below Figure 1

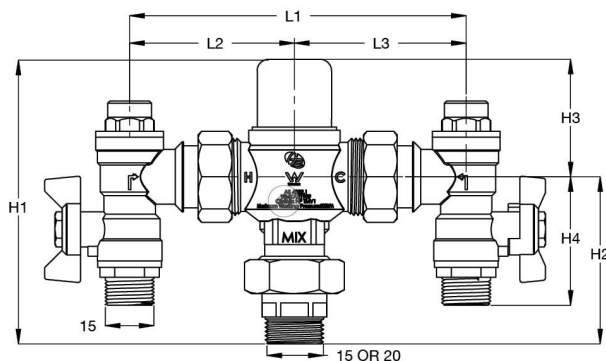

Part Number	D1	L1	L2	L3	H1	H2	H3	H4
CliniMix <sup>®</sup> TMV1 Std 1/2" BSP Outlet	1/2" BSP/ 15mm	145	72.5	217	125	80	50	55
CliniMix <sup>®</sup> TMV1 Optional 3/4" BSP Outlet Adaptor	3/4" BSP/ 20mm	145	72.5	217	125	80	50	55

**All dimensions in mm unless otherwise stated.**

Figure 1 – Physical Size CLINIMIX<sup>®</sup> TMV – NICKEL PLATED FINISH with 1/2" Male Thread Inlet and Outlet Fittings.

Figure 2 shows a general arrangement drawing of the Galvin Engineering CliniMix<sup>®</sup> Thermostatic Mixing Valve showing the method of operation. Hot and cold water is supplied to each side of the TMV respectively. The hot water enters through a port below the piston; the cold water enters above the piston. Upon entry the water begins to blend and enters the Mixing Tube. At this point the mixed water contacts the thermostatic wax element. The element will expand or contract to match the water temperature it is exposed to causing the piston to move, thereby regulating the amounts of hot and cold water entering the TMV. This thermostatic mechanism maintains the mixed water temperature at a constant temperature.

If for example the inlet hot pressure dropped and the flow of hot water into the TMV were reduced and the TMV would react as per the following sequence of events:

- Element is exposed to mixed water at a reduced temperature.
- Thermostatic element contracting.
- Piston is pushed upwards, by the return spring, restricting cold flow, consequently opening more of the hot port.
- TMV attempts to restore itself to its original temperature setting.

Similarly, if the hot inlet temperature dropped, the element would again see blended water at a lower temperature and therefore the Element would contract reducing the cold port piston gap and hence supply more hot water and less cold. Once again the TMV attempts to restore itself to its original setting. This will occur for all changing conditions including changes to flow rate, inlet temperatures and inlet pressure.

In the event of a sudden loss of the cold water supply the Piston will shut off the hot port thus stopping any flow through the valve. The valve will also shut down the cold supply if there is a hot water failure.

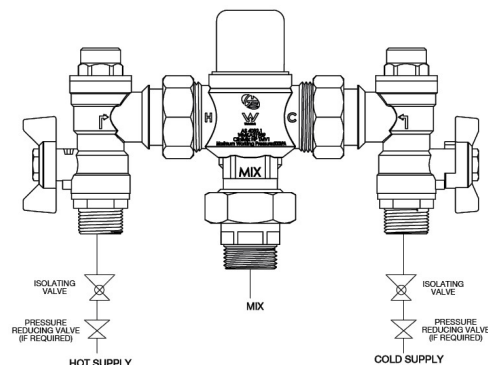

TECHNICAL DATA		
<b>MIXED OUTLET TEMPERATURE</b>		
Preset Temperature		43.5°C
<b>INLET TEMPERATURES</b>		
Cold Supply (°C)	Min	5
	Max	30
Hot Supply (°C)	Min	55
	Max	90
Hot to Mix Temperature Differential for Stable Operation (°C)	Min	10
Cold to Mix Temperature Differential for Stable Operation (°C)	Min	5
Nominal Flow Rate (LPM) (Per Graph)	Min	6
<b>DYNAMIC INLET PRESSURES</b>		
Hot and Cold Inlet Pressures	Min	20
	Max	500
<b>STATIC INLET PRESSURE</b>		
Hot and Cold Inlet Pressures (kPa)	Max	1000
<b>INLET PRESSURE RATIO</b>		
Maximum Inlet Pressure Ratio for Stable Operation (Either supply) (Hot ; Cold or Cold : Hot)		6:1
NOTE 1: for optimum operation it is recommended that the hot and cold water supply pressure be balanced to within +/- 10%		
NOTE 2: Notwithstanding the above, compliance with AS/NZS3500 must be maintained.		

## FLOW SIZING GRAPH

The Galvin Specialised CliniMix® Thermostatic Mixing Valve is suitable for many applications. The Head-loss Characteristic for Mixed Outlet Flow rate versus Balanced Inlet Pressure is shown below in Graph 1. It is important that the valve is not oversized for its intended application.

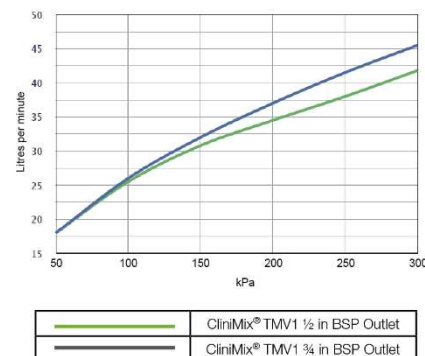

GRAPH 1 – Head-loss Characteristics

**NOTE:** To ensure optimum performance the minimum outlet flow of the TMV during operation should be at least 6 litres/minute.

It is important that the valve is sized such that the flow rates from the outlets are not less than those listed AS/NZS 3500.1.2.

The pipe-work between the TMV and the system must be sized in accordance with AS/NZS 3500.1.2 to ensure the water velocity in the pipe-work is within the allowed limit.

If the TMV is to be installed and operated under unequal inlet pressures, the lower inlet pressure determines the outlet flow rate. However, for optimum performance and stability it is recommended that the TMV be installed with balanced dynamic inlet pressures (+/- 10%).

## INSTALLATION

The Galvin Specialised CliniMix<sup>®</sup> Thermostatic Mixing Valve must be installed using the appropriate Standard, Code of Practice and legislation application to each state and following the details outlined in this section.

The Galvin Specialised CliniMix<sup>®</sup> must be installed by a licensed plumber, or where applicable, a licensed plumber who has undertaken T.A.F.E. training in Thermostatic Mixing Valves.

Note: To effectively control microbial hazards during system design, installation, commissioning and maintenance, the requirements outlined in AS/NZ3666 and local legislation shall be adhered to.

Inlets and outlet connections of the TMV are clearly marked. The letters H and C cast into the Thermostatic Mixing Valve body indicates the Hot and Cold Inlet respectively. An arrow cast into the body of the inlet and isolation valves identifies the TMV outlet direction.

If the TMV is not installed correctly then it will not function correctly and may put the user in danger. It may also void the warranty of the TMV.

Prior to the installation of the TMV, the system must be checked to ensure that the system operating conditions fall within the recommended operating range of CliniMix<sup>®</sup> Thermostatic Mixing Valve as detailed in Section 5. If the hot water supply temperature is greater than 90° Celsius, the TMV may be damaged. A suitable temperature limiting valve must be fitted to the hot water supply, prior to the inlet fittings, if the temperature of the hot water will rise above 90° Celsius. This temperature limiting valve must be installed as per the manufacturer's instructions. It is important that both of the inlet dynamic supply pressures are 500kPa or less. If either supply pressure exceeds 500kPa then a suitable pressure reducing valve must be fitted prior to the inlet control valve to reduce the pressure to an acceptable limit. These pressure reducing valves must be installed as per the manufacturer's instructions. In order to achieve optimum performance from the TMV it is recommended that the inlet pressures are balanced to within +/-10% of each other.

The water quality conditions should be checked to ensure they do not exceed the limits as listed in AS/NZS 3500.4, Section 3.7.1. If they do exceed these limits, then it will be necessary to install a water softener or water treatment device.

NOTE: In some installations, certain types of control devices such as flick mixers and solenoid valves are used. The water pressure may be seen to spike outside that recommended, for the TMV, during rapid shut off conditions with these types of devices. Even if the spike only lasts a split second it is still considered to be outside the operating conditions and may cause the TMV to operate incorrectly. In the event that this does occur, measures must be taken to control the spike, such as the installation of an inline pressure reducing valve directly before the valve inlets.

To ensure that the TMV operates correctly, it is necessary that the pipe-work is thoroughly flushed with clean water before the TMV is installed. This will remove any physical contaminants from the pipe-work, ensuring trouble-free operation. During the flushing procedure, care should be taken to prevent water damage occurring to the surrounding area.

It is a requirement of AS/NZS3500.4, Section 3.3 (a) that "Each thermostatic mixing valve shall have an isolating stop tap/valve, line strainer and non-return valve fitted to the hot and cold water supply lines". The inlet fittings supplied with each TMV will ensure this requirement is met. If the Galvin Specialised CliniMix<sup>®</sup> Thermostatic Mixing Valve is to be installed without the supplied inlet control valves then it will not be an approved product.

Strainers must be fitted to prevent any particulate contamination from entering the TMV. These strainers should be 60 Mesh stainless steel. Isolating valves are required so that the water supply to the TMV can be isolated in the event that servicing is required. Non-return devices must also be fitted to both the hot and cold inlets to prevent cross-contamination.

Ensure that the test plugs in the top of the inlet fittings are tight.

The TMV should be installed so it can be easily accessed for maintenance or servicing. The valve can be installed in a wall cavity, under a basin or on a wall; however it is essential that the mixing valve and inlet fittings are easily accessible for servicing.

During installation or servicing, heat must not be applied near the TMV or inlet fittings, as this will damage the valve and inlet fittings internals. It will put the user at risk, and it will void the warranty of the TMV.

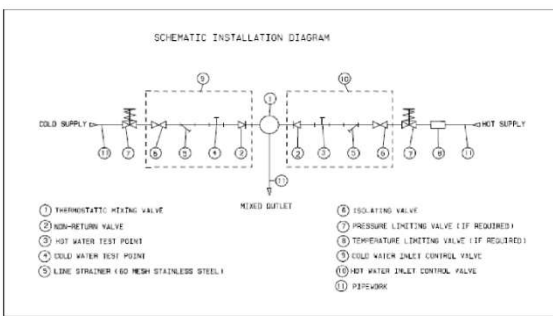

Note: The Galvin Specialised CliniMix® Thermostatic Mixing Valve is intended mainly for use in applications with set temperatures below 45° Celsius. When installed at higher set temperature, the performance may be less than specified in AS4032.1. In such situations consideration should be given to the question of whether an alternative device, i.e. a tempering valve approved to AS4032.2 would provide a greater margin for safety in reducing scalding accidents.

## COMMISSIONING OF THE VALVE

Upon completion of the installation, the TMV must be tested and commissioned as per the procedure outlined below. The entire procedure should be read through thoroughly prior to the commissioning of the TMV. A calibrated digital thermometer having rapid response time with maximum temperature hold, a small flat bladed screwdriver, adjustable spanner and the adjusting key (supplied with the TMV) will be required to check and set out the outlet mixed temperature of the TMV.

- Ensure all outlets that will be serviced by the TMV have adequate warning signs posted to ensure that no outlet is used during commissioning.
- Open the cold supply line to the valve, and then open the hot water supply line, ensuring there are no leaks.
- Open the outlet that is serviced by the shortest length of pipe work between the mixing valve and outlet fixture.
- Allow the mixed outlet to flow for at least 60 seconds to allow the temperature to stabilise before taking a temperature reading at the outlet with a digital thermometer. The flow rate should be at least 6 L/min. The flow rate can be checked with the aid of a known size container and a stopwatch.
- If the outlet temperature requires adjustment the following steps are requires;

### TEMPERATURE ADJUSTMENT

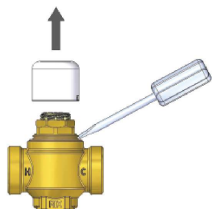

1. Using a small flat bladed screwdriver lever the protected cover off the TMV (figure 3).

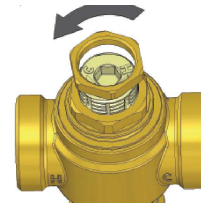

2. Release the Temperature Locking Nut with an adjustable spanner.

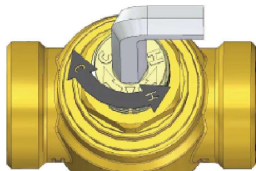

3. Fit the supplied key over the adjusting spindle (figure 3).  
To **increase** the mixed outlet temperature, rotate the spindle **anti-clockwise**.  
To **decrease** the mixed outlet temperature, rotate the spindle **clockwise**.

4. Allow the mixed outlet temperature to stabilize for 60 seconds and once again take a temperature reading. Repeat the procedure until the desired temperature has been reached.

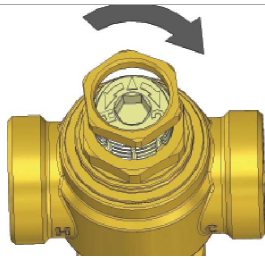

5. Retighten the Temperature Locking Nut with an adjustable spanner

7. Check the outlet temperature is stable over a full range of flow rates and that the flow rate is adequate for the application.



6. Push the top cover firmly on to the top of the valve until it 'snaps' back into place.

8. Close the outlet. The TMV is now set and locked.

### **SHUT DOWN TEST**

Now that the TMV has been set and locked it is necessary to perform a shutdown check. Allow the mixed water temperature to stabilize and note the outlet temperature. While holding a digital thermometer in the outlet flow, quickly isolate the cold water supply to the valve. The outlet flow should quickly cease flowing. As a rule of thumb the flow should be less than 0.1L/min following the isolation. Monitor the maximum outlet flow temperature, and record this on the Commissioning Report (Appendix A). The temperature should not exceed that allowed by the applicable standard or code of practice for each state and territory. Restore the cold water to the TMV. After the mixed water temperature has stabilized note the outlet temperature ensuring the outlet temperature has reestablished.

Now repeat the above test, except this time quickly isolate the hot water supply to the valve. The outlet should quickly slow to a trickle. As a rule of thumb, the trickle should typically be less than 0.4L/min @ 500kPa down to less than 0.1L/min @ 100kPa following the isolation. Restore the hot water supply to the valve and measure and record the outlet temperature has stabilized ensuring the outlet temperature has reestablished.

Ensure that all details of the Commissioning Report are completed and signed by the relevant signatories. A copy of this report should be kept with the installer and owner of the premises.

The valve is now commissioned and it can be used within the technical limits of operation.

### **MAINTENANCE AND SERVICING**

The Galvin Specialised CliniMix® Thermostatic Mixing Valve will only require minimal preventative maintenance work to ensure it operates at its optimum level of performance. The valve should be commissioned and serviced annually, unless the installed conditions dictate more frequent servicing is necessary.

#### **ANNUAL MAINTENANCE PROCEDURE**

The Galvin Specialised CliniMix® TMV should be inspected and tested annually. The valve should be given a light wipe down of the external surface. The TMV and surrounding areas should be inspected for leaks or water damage and appropriate action taken if required.

Ensure a clean dry work area is available. Firstly, isolate the hot and cold supplies to the TMV by closing the inlet ball isolators. Remove the inlet fitting top cover with a suitable spanner and then remove the mesh strainer. Clean with a de-scaling solvent (such as CLR), check for physical damage and then thoroughly rinsed with clean water. The strainers can then be re-installed into the valve, and the top cover replaced and tightened to a maximum torque of 15Nm into the hot and cold inlet service fitting.

If the TMV fails to shut down or fails to maintain its set temperature, then refer to the fault finding solutions outlined in Section 8.

The valve piston o-ring and thermostatic element / piston assembly must be replaced at intervals not exceeding 5 years.

Check that the test plugs in the top of the inlet fittings are tight and that there is no evidence of water leakage. The TMV must then be recommissioned as per Section 8, including temperature adjustment and the shutdown test.

### **INSTALLATION INSTRUCTIONS FOR THERMOSTATIC ELEMENT/PISTON ASSEMBLY**

1. Ensure a clean dry work area is available.
2. Isolate the hot and cold supplies to the mixing valve by closing the inlet ball valves.
3. Pry off the plastic cap using a small screwdriver or similar.
4. Remove brass Top Assembly with a suitable spanner. Care must be taken to ensure that the underside of the Top Assembly does not receive even the slightest damage.
5. Gently remove the element/piston assembly.
6. Lightly grease O-rings if required. (use only potable water approved silicon-based lubricating grease such as Molykote111)
7. Insert new element/piston assembly taking extreme caution not to damage any surface of the piston.
8. Refit the TMV Top assembly back to the body and tighten to a maximum torque of 10Nm.
9. The valve must then be recommissioned as per section 8 including temperature adjustments and shut down test.

### **INSTALLATION INSTRUCTIONS FOR O-RING REPLACEMENT**

1. Ensure a clean dry work area is available
2. Isolate the hot and cold supplies to the TMV by closing the inlet isolator valves.
3. Pry off the plastic cap by using a small screwdriver or similar
4. Remove brass top assembly with a suitable spanner. Care must be taken to ensure that the underside of the cap does not receive any damage.
5. Remove o-ring from thread of top assembly. Replace the largest o-ring supplied in the kit (adequately grease o-rings with potable water approved silicon-based lubricating grease such as Molykote 111 before refitting).
6. Carefully remove the spindle from the center of the body.
7. Remove o-ring from spindle. Replace with o-ring supplied in the kit. (adequately grease o-rings with a potable water approved silicon-based lubricating grease such as Molykote111 before refitting).
8. Insert cartridge assembly taking extreme caution not to damage any surface of the piston.
9. Refit the TMV top assembly back to the body and tighten to a maximum torque of 10Nm.
10. The valve must be recommissioned as per section 8 including temperature adjustments and the shutdown test.

## SPARE PARTS

Part	Replacement Period
O Ring Kit	5 yearly
Thermostatic Element Assembly (incl. Thermostatic Element/Piston Assembly)	5 yearly
Face Seal Washer	As required
Inlet Fitting Strainer (two)	As required

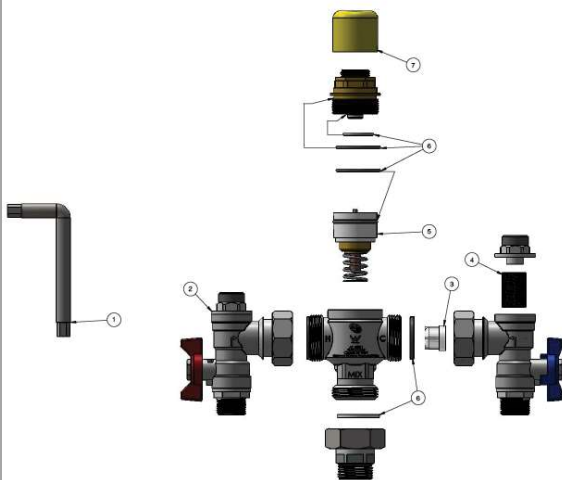

ITEM	ITEM NO.	SALES SPARE DESCRIPTION	QTY
1	WM-KEY-1	TEMPERATURE ADJUSTMENT KEY FOR WM-TMV1	1
2	WM-ISO-1	INLET ISOLATOR ELBOWS (PAIR) FOR WM-TMV1	1
3	WM-NRV-1	INLET NON-RETURN VALVE FOR WM-TMV1 (PAIR)	2
4	WM-STR-1	INLET STRAINERS FOR WM-TMV1 (PAIR)	2
5	WM-TPKIT-1	THERMOSTAT, PISTON/SHUTTLE ASSEMBLY & SPRING FOR WM-TMV1	1
6	WM-SKIT-1	SEAL & O-RING KIT FOR WM-TMV1	1
7	WM-ATC-1	ANTI TAMPER CAP FOR WM-TMV1 (YELLOW)	1

NOTES: IF THE ITEM NUMBER IS NOT LISTED, THE COMPONENT IS NOT AVAILABLE INDIVIDUALLY



## WARRANTY

The Galvin Engineering CliniMix® Thermostatic Mixing Valve is guaranteed free from manufacturing faults for a period of 12 months, subject to the conditions and exclusions set out below;

### **GALVIN ENGINEERING PRODUCT WARRANTY**

Galvin Engineering products are warranted to be free from defects in materials and/or workmanship for a period of 12 months service life, and if found by Galvin Engineering to be so defective will be replaced as set out below. If the product is sold by a party other than Galvin Engineering, then it is sold by the seller as principal and the seller has no authority from Galvin Engineering to give any additional warranty on behalf of Galvin Engineering.

The benefits of this warranty are in addition to all other rights and remedies which the purchaser may have under the Trade Practices Act or similar laws of each State and Territory in Australia.

### **Warranty Conditions and Exclusions**

#### Conditions:

1. The Thermostatic Mixing Valve (TMV) must have been installed by a licensed plumber in accordance with this document and in accordance with the National Plumbing and Drainage Code AS/NZS3500 (the Code) current at the date of installation and all relevant statutory and local requirements in the State or Territory in which the product is installed.
2. Where the product is installed outside the boundaries of a metropolitan area as defined by Galvin Engineering, the cost of transport insurance and travelling shall be the purchaser's responsibility.
3. Where the TMV comprises part of a hot water system, installation of that system must be in accordance with its manufacturer's recommendation, the Code and all relevant statutory and local State or Territory requirements.
4. The TMV must be returned to Galvin Engineering together with a fully and correctly completed Galvin Engineering Warranty Claim Form.
5. Where the valve is replaced under warranty the replacement TMV carries a new warranty as detailed herein.

#### Exclusions:

Replacement work will be carried out as set out in the Galvin Engineering Warranty above, but the following exclusions may cause the warranty to become void, and may incur a service charge including cost of parts where:

1. Damage has been caused by accident, Acts of God, misuse, incorrect installation, incorrect installation of the water supply system of which the product forms a part of attempts to disassemble the TMV.
2. It is found that there is nothing wrong with the product
3. The failure of the TMV is due in part or in whole to faulty manufacture/installation of the hot water supply system of which the product forms part.
4. The TMV has failed directly or indirectly as a result of excessive water pressure or temperature outside the Application Guidelines, thermal input or corrosive environment.
5. The TMV has failed due to foreign matter either from installation or the water supply.
6. The failure of the TMV is due to scale formation in the waterways of the TMV.
7. The failure of the TMV is due in part, or in whole, to installation not in conformance with the requirements of the Code.
8. Galvin Engineering reserves the right to change its specifications without prior notice and will not accept liability for any claim arising from such change.
9. Subject to any statutory provisions to the contrary, claims for damage to furniture, carpets, walls, foundations or any other consequential loss either directly or indirectly due to leakage from the TMV are also excluded from warranty cover.

## Product Installation Guideline

Version 1, 27 March 2018, 10 of 14

### TROUBLESHOOTING

PROBLEM	CAUSE	RECTIFICATION
The desired mixed water temperature cannot be obtained.	<ul style="list-style-type: none"> <li>Hot and cold supplies are fitted to the wrong connections</li> <li>Valve contains debris.</li> <li>Strainers contain debris.</li> </ul>	<ul style="list-style-type: none"> <li>Ensure the valve has the Hot/Cold supplies fitted to the correct connections.</li> <li>Clean valve ensuring debris is removed and components are not damaged.</li> <li>Clean strainers ensuring debris is removed.</li> <li>Check non return device is not jammed. Clean if necessary.</li> </ul>
The valve will not shut down.	<ul style="list-style-type: none"> <li>The hot to mix temperature differential is not high enough.</li> <li>Sealing seat is damaged or fouled by debris</li> </ul>	<ul style="list-style-type: none"> <li>Raise hot water temperature.</li> <li>Replace piston O-rings</li> <li>Clean seat.</li> <li>Replace element assembly</li> </ul>
Mix temperature unstable.	<ul style="list-style-type: none"> <li>Debris is fouling valve.</li> <li>Flow rate below 6 L/min.</li> <li>Strainers are fouled.</li> <li>Systems may be fluctuating outside valve parameters</li> </ul>	<ul style="list-style-type: none"> <li>Clean the valve ensuring that all debris is removed and components are not damaged.</li> <li>Rectify any pressure deterioration.</li> <li>Clean strainers</li> <li>Check system pressure; install pressure control valves to ensure inlet conditions are within limit</li> </ul>
Mix temperature changing over time.	<ul style="list-style-type: none"> <li>Inlet conditions (pressures or temperatures) are fluctuating.</li> <li>Strainers contain debris.</li> </ul>	<ul style="list-style-type: none"> <li>Install suitable pressure control valves to ensure inlet conditions are within range.</li> <li>Clean strainers ensuring debris is removed.</li> </ul>
Either full hot or cold flowing from the outlet fixture.	<ul style="list-style-type: none"> <li>Valve is incorrectly set.</li> <li>Hot/Cold water has migrated to other inlet</li> </ul>	<ul style="list-style-type: none"> <li>Adjust mix temperature between 35 – 48 Degrees Celsius as required.</li> <li>Replace faulty non-return valves</li> </ul>
No flow from the valve outlet.	<ul style="list-style-type: none"> <li>Hot or cold water failure.</li> <li>Strainers are fouled</li> </ul>	<ul style="list-style-type: none"> <li>Valve functioning correctly. Restore inlet supplies and check mix temperature.</li> <li>Clean strainer.</li> </ul>
Flow rate reduced or fluctuating	<ul style="list-style-type: none"> <li>Valve or inlet fittings fouled by debris.</li> <li>Dynamic inlet pressures are not within those recommended limits.</li> </ul>	<ul style="list-style-type: none"> <li>Check valve and inlet fittings for blockages.</li> <li>Ensure the dynamic inlet pressures are nominally balanced to within +/- 10%</li> </ul>
Mixed water temperature too hot or cold.	<ul style="list-style-type: none"> <li>Valve has been tampered with.</li> <li>Valve incorrectly set.</li> <li>Inlet temperatures are not within specified limits.</li> </ul>	<ul style="list-style-type: none"> <li>Readjust valve to required set temperature.</li> <li>Readjust valve to required set temperature.</li> <li>Ensure inlet temperatures are within the specified limits.</li> </ul>
Temperature adjuster difficult to move.	<ul style="list-style-type: none"> <li>Adjustment at maximum mix temperature stops.</li> <li>Valve piston over set.</li> </ul>	<ul style="list-style-type: none"> <li>Mixed water is at maximum temperature no higher mix.</li> <li>Wind adjuster out until set temperature required is achieved.</li> </ul>
Hot water flows into the cold water system or vice versa.	<ul style="list-style-type: none"> <li>Non return valves faulty.</li> </ul>	<ul style="list-style-type: none"> <li>Replace non-return valves.</li> </ul>
Valve is noisy.	<ul style="list-style-type: none"> <li>Water velocity above velocity requirements of AS3500.1.2.</li> </ul>	<ul style="list-style-type: none"> <li>Reduce water velocity.</li> </ul>



# Galvin Specialised Thermostatic Mixing Valve or Tempering Valve Commissioning Report and/or Maintenance Report

**Note:**

1. Please use a separate form for each valve.
2. The original copy of the report is to be given to the owner/occupier and retained on site for a minimum of 7 years.

Cross off appropriate box

Thermostatic Mixing Valve                       Tempering Valve

Commissioning Report                       Maintenance Report

Name of Establishment: \_\_\_\_\_

Address of Establishment: \_\_\_\_\_

Phone Number: \_\_\_\_\_ Date: \_\_\_\_\_ Work Order #: \_\_\_\_\_

Contact Person: \_\_\_\_\_

Make & Model of Hot Water System: \_\_\_\_\_

Temperature of Hot Water to the Valve: \_\_\_\_\_ Temperature of Cold Water to the Valve: \_\_\_\_\_

Hot Water Pressure: \_\_\_\_\_ kPa Cold Water Pressure: \_\_\_\_\_ kPa

Make of Mixing Valve: \_\_\_\_\_ Model No: \_\_\_\_\_ Size: \_\_\_\_\_

Valve Location/Building: \_\_\_\_\_

Valve Identification No: \_\_\_\_\_

Total No of Valves on the Site/Building: \_\_\_\_\_

No of Outlets Serviced by this Valve: Baths ( ) Basins ( ) Showers ( )

Other Outlets - Details \_\_\_\_\_ + \_\_\_\_\_

Valves Installed to the requirements of:

The NSW Code of Practice Plumbing and Drainage	Yes	No
The HOSPLAN Code of Practice for Thermostatic Mixing Valves in Health Care Facilities	Yes	No
The Valves manufacturers requirements	Yes	No
AS4032.3	Yes	No
The specifications and drawings for the project	Yes	No
The Local Water Supply or Authority	Yes	No

If No, give details and actions taken:

\_\_\_\_\_  
\_\_\_\_\_  
\_\_\_\_\_

# Galvin Specialised Thermostatic Mixing Valve or Tempering Valve Commissioning Report and/or Maintenance Report

## Test Results

Valve considered satisfactory for use: Yes  No

If No, state the reason and action taken: \_\_\_\_\_  
\_\_\_\_\_  
\_\_\_\_\_

## Commissioning Work

It is hereby certified that all the commissioning work has been carried out by the undersigned in accordance with the requirements of the Codes of Practice indicated prior.

Date of Valve Commissioned: \_\_\_\_\_

Name of Licensed Plumber: \_\_\_\_\_ License/Cert No: \_\_\_\_\_

License Plumbers Signature: \_\_\_\_\_

Telephone No. \_\_\_\_\_

Owner/occupiers signature: \_\_\_\_\_ Date: \_\_\_\_\_

Date of Initial Service Due: \_\_\_\_\_

# Galvin Engineering Thermostatic Mixing Valve or Tempering Valve Commissioning Report

Valve Location/Building : \_\_\_\_\_

Room or Area: \_\_\_\_\_

Work Order No.: \_\_\_\_\_

Warm Water Outlet Fixture No.	*Name/Type/Size and location of Outlet Fixture (Bath, Shower, Basin, Other)	Flow rate of Design Water (LPS)		Temp of Warm Water (C)	
		One Outlet in Use	**All Req'd Outlets in Use	One Outlet in Use	**All Req'd Outlets in Use
1.					
2.					
3.					
4.					
5.					
6.					
7.					
8.					
9.					
10.					
11.					

\*Give details of brand and model designation.

\*\* Commensurate with the design flow rate for the mixing valve.

Note: An accurate digital thermometer is necessary for the temperature measurements

Prescribed temperature range for warm water \_\_\_\_\_ C to \_\_\_\_\_ C

Thermal shutdown at both minimum and maximum design flow rates

(Passed/Failed) Yes  No  Name of Plumber: \_\_\_\_\_

License/Cert No. \_\_\_\_\_

Licensee's Signature: \_\_\_\_\_ Date: \_\_\_\_\_

Telephone Number: \_\_\_\_\_

# Galvin Engineering Thermostatic Mixing Valve or Tempering Valve Commissioning/Maintenance Report

The following information is to be provided by the site manager/owner/occupier.

Valve size and installation recommended by : \_\_\_\_\_

Valves supplied by: \_\_\_\_\_

Date of Installation: \_\_\_\_\_ Drawing No. \_\_\_\_\_

Service Manual on Site:            Yes             No

Commissioning Tests for new installation or valve replacement. Yes

This set of testing procedures and report received and witnessed by (Print Name): \_\_\_\_\_

\_\_\_\_\_

Temperature setting at completion of commissioning \_\_\_\_\_ C

Position: \_\_\_\_\_ Signature: \_\_\_\_\_

Date: \_\_\_\_\_

**Maintenance Tests. Yes**

Date of Previous Service: \_\_\_\_\_

Previous Service carried out by: \_\_\_\_\_

Reason for Maintenance Tests: \_\_\_\_\_

This Test and report Witnessed by: \_\_\_\_\_

The valve has been operating/performing satisfactorily for the previous 12 months: Yes             No

Comment on monthly Temperature Tests carried out by the owner: \_\_\_\_\_

\_\_\_\_\_

Temperature setting at time of completion: \_\_\_\_\_ C

Current Report received and witnessed by:

Name: \_\_\_\_\_

Position: \_\_\_\_\_

Signature: \_\_\_\_\_ Date: \_\_\_\_\_